

SENSOR COMBINATION SOAP/DISINFECTANT/LOTION WP575E



298 x 298 x 121 mm

Sensor 950 ml soap, 950 ml disinfectant, 950 ml lotion

- Sensor combination consisting of a sensor liquid soap-, disinfectant- and lotion dispenser in robust, germ-reducing and easy-care stainless steel (AISI 316L).
- All-stainless steel housing; all corners fully welded, visible surfaces satin finished and brushed. Further available surfaces: see below.
- Sensor soap or lotion dispenser with EWAR® eModule touch-free operated and non-drip soap and lotion pump. Designed for standard 950 ml disposable bottles of liquid soap or lotion. Also refillable with large container using the plug-in tank as an option
- Sensor disinfectant dispenser with EWAR® eModule touch-free operated disinfectant pump with 950 ml tank arranged in the middle. Designed for standard disinfectants. Note: Not approved for medical areas.
- Inspection slots to indicate fill level.
- Accessible for refilling through lockable, hinged housing.
- Keyed alike cylinder lock in corrosion-resistant zinc die-casting.
- eModule battery-powered with two 1.5 V Baby/LR14 batteries. Power supply available as an option.
- Wear parts can be replaced as modules.
- Mounting: With four screws through key holes and one optional anti-theft hole in the back wall.
- Delivery includes fixing material, batteries and first fill with soap and lotion.
- Weight, including single package: 6.4 kg



Suggested text for specifications:

Sensor combination consisting of a sensor liquid soap, disinfectant and lotion dispenser in stainless steel (AISI 316L) for surface mounting. All-stainless steel housing; all corners fully welded, visible surfaces satin finished and brushed. Sensor soap or lotion dispenser with touch-free operated and non-drip soap or lotion pump. Designed for standard 950 ml disposable bottles of liquid soap or lotion. Sensor disinfectant dispenser with touch-free operated disinfectant pump with 950 ml tank arranged in the middle. Designed for standard disinfectants. Inspection slots to indicate fill level. Accessible for refilling through lockable, hinged housing. Keyed alike cylinder lock in corrosion-resistant zinc die-casting. Delivery includes fixing material, batteries and first fill with soap and lotion. Dimensions: 298 x 298 x 121 mm
Article No. WP575e

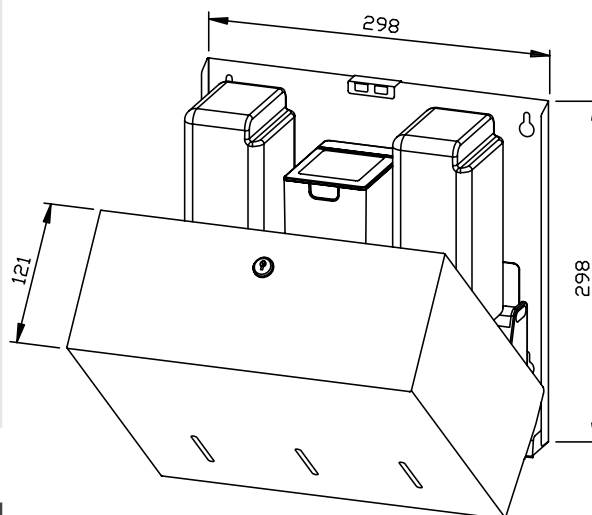

Options	ID No.
Plug-in tank	937 201
Power supply for eModule	923 060
Available surfaces	ID No.
satin finished (standard)	727 735
highly polished	731 735
(coloured) plastic powder-coating	728 735

Ernst Wagner GmbH & Co. KG

Ernst-Abbe-Straße 21 · D-72770 Reutlingen · Tel.: +49712151539-0 · Fax: -20
info@wagner-ewar.de · www.wagner-ewar.de

WAGNER
EWAR